



TH510

High precision control modular programmable temperature/humidity controller



Selection Guide

Display unit	Input and output	Language	Model
Display (5.7" TFT LCD) [1]	8-point input/6-point output (1 module) + power module + control module[1]	Korean, English, Chinese (Simplified) [S]	TH510-11S
	8-point input/14-point output (2 modules) + power module + control module[2]	Korean, English, Chinese (Simplified) [S]	TH510-12S
	16-point input/16-point output (3 modules) + power module + control module[3]	Korean, English, Chinese (Simplified) [S]	TH510-13S
	No input/output, No power module/control module [N]	Korean, English, Chinese (Simplified) [S]	TH510-1NS

Product composition

Category	Description	Model
Display unit	Display unit (5.7" TFT LCD)	TH510-1ND
Control module	Temperature/humidity control module	TH510-MAIN
Power module	Power module	TM-PWR
Input module	16-point input module	TM-DI
Output module	8-point output module	TM-DO
Input/output module	8-point input/6-point output module	TM-DIO

h Suffix code

Category	Code			Description
TH510-	<input type="checkbox"/>	<input type="checkbox"/>	<input type="checkbox"/>	Programmable temperature/humidity controller, 145(W) X 145(H)
Display	1			Display (5.7" TFT LCD)
	N			None
Input/output	1			8-point input/6-point output (1 module) + power module + control module
	2			8-point input/14-point output (2 modules) + power module + control module
	3			16-point input/16-point output (3 modules) + power module + control module
	N			No input/output
Language		S		Korean, English, Chinese (Simplified)

* The basic components of this product are "display/power module/control module/input module/output module."
 (Contact input can be configured to a maximum of 32 points. Contact output can be configured to a maximum of 32 points.)

h Range and input type

Input type			Temperature		Humidity	
			Measurement range (°C)	Precision	Measurement range (%RH)	Precision
Resistance temperature detector (RTD)	Pt100 Ω	Pt-1	-100.0 to 300.0	±0.1% of FS ±1 Digit	0.0 to 100.0	±1% of FS ±1 Digit
		Pt-2	-100.00 to 150.00			
	KPt100 Ω	KPt-1	-100.0 to 300.0			
		KPt-2	-100.00 to 150.00			
Volts direct current (VDC)	1 - 5 V		-100.0 to 300.0	±0.1% of FS ±1 Digit		
	0 - 30 V		-100.0 to 300.0			

Specifications

Category		Description
Input	Input calibration (sensor bias)	1-point temperature: EUS (0 - 100%) 1 point humidity: EUS (0 - 100%)
	Dry/Wet bulb sensor calibration	After removing the cover of the wet bulb sensor, calibrate the difference between dry and wet bulb sensors.
	Scaling	VDC: Input scaling based on the conversion range
	Input filter (LPF)	0 to 120 seconds
Control mode	Select operation mode	Select static control/program control
Control output	Temperature control output	Select SSR output or SCR (4 - 20 mA d.c.) output
	Humidity control output	
Control action	Pattern	100 Patterns (1 Pattern/100 Segments)
	Segment	2,000 segments
	PID group	16 groups (4 temperature zones × 4 humidity zones)
	Auto tuning	Auto tuning based on set target values
	Proportional band	0.00 to 100.00% (ON/OFF control at 0.00%)
	Integral time	0.0 to 3,000 seconds (OFF when set to 0 seconds)
	Derivative time	
	ON/OFF control	Set the proportional band (PB) to 0.0
	Direct action/Reverse action	Based on the selection of direct or reverse action for the control output
Retransmission	Temperature/Humidity	4 - 20 mA d.c. Select from the following: Process Value (PV), Set Value (SV), Manipulated Output Value (MV)
	Scaling	Auto-scales the set upper/lower limit range (4 - 20 mA d.c.)
Alarm settings	Configured alarms	System alarms: 8 points (with 4 points allocated per pattern for a total of 8 pattern alarms)
	Alarm type	Absolute upper/lower limits, deviation upper/lower limits, within/outside the range (alarm direction, hold)
	Absolute alarm range	EU (0 to 100%)
	Deviation alarm range	EUS (-100 to 100%)
	Hysteresis	EUS (0 to 100%)
Display specifications	Screen dimensions	TFT color LCD (115.2 × 86.4 mm)
	Resolution (number of pixels)	640 × 480 pixel
	Back light	LED Back light
	Back light life	Approximately 40,000 h
	Touch type	Resistive (4 Wires)
	Language	Korean/English/Chinese (Simplified)
Memory specifications	Internal memory	Non-volatile memory: 80 MB - Stores for 15 days at 1-second intervals
	External memory	SD card (8 GB): Stores for 1 year at 1-second intervals
	Storage intervals	1 to 360 seconds
	Memory information	Saves and restores program information and settings, and saves temperature/humidity set values/process values/output values
Installation environment	Ambient temperature	Operating environment: 0 to 50 °C / Storage environment: -20 to 70 °C
	Temperature change	Operating environment: 10 °C/h or lower / Storage environment: 20 °C/h or lower
	Ambient humidity	Operating environment: 20 to 90% RH (however, there should be no condensation) / Storage environment: 5 to 95% RH (however, there should be no condensation)
	Magnetic fields	400 A/m or lower
	Elevation	2,000 meters above sea level or below
Influence of ambient temperature	VDC	±0.003% of FS / °C
	RTD sensors	±0.03 °C/°C
Certification		CE
Weight		Approximately 1.32 kg

Category		Description	
Power input	Power voltage	100 - 240 V a.c. Voltage fluctuation rate: $\pm 10\%$	
	Power frequency	50 - 60 Hz	
	Power consumption	30 VA max	
	Maximum internal fuse rating	250 V a.c.	
	Dielectric strength	Primary and secondary terminals: minimum 1,500 V a.c. for 1 min Primary and FG terminals: minimum 1,500 V a.c. for 1 min Secondary and FG terminals: minimum 1,500 V a.c. for 1 min	
	Insulation resistance	20 M Ω or 500 V d.c. between the power terminal and the FG terminal	
Sensor input	Input type	2 types of RTD (Pt-100, KPt-100), 2 types of VDC (1 - 5 V, 0 - 30 V)	
	Sampling frequency	250 ms	
	Current measured by RTD	Approximately 0.21 mA	
	Input resistance	VDC: 1 M Ω or higher	
	Allowable wiring resistance	RTD: maximum 10 Ω /wire, VDC: 2 K Ω or lower	
	Influence of wire resistance	RTD: ± 0.3 $^{\circ}\text{C}/10$ Ω (however, the wire resistance of 3 wires should be identical)	
	Allowable input voltage	VDC: ± 33 V d.c. or lower	
	Sensor burn-out detection	UP-Scale at burn-out	
Digital output (DO)	Relay contact Maximum 32 points	Contact A	30 V d.c. 3 A max, 250 V a.c. 3 A
		Contact B	NO: 30 V d.c. 5 A max, 250 V a.c. 5 A
Control output	SSR Output	ON: 18 V d.c. Pulse voltage (load resistance of 800 Ω or higher)	
	SCR Output	4 - 20 mA d.c. (Load resistance of 600 Ω or lower)	
Retransmission	Current output	4 - 20 mA d.c.	
	Load resistance	Load resistance of 600 Ω or lower	
	Output limit	-5.00 - 105.00%	
	Output type	Process Value (PV), Set Value (SV), Manipulated Output Value (MV); arbitrary selection	
	Update frequency	250 ms	
Digital input	Maximum number of inputs	32 points	
	Input format	Dry contact input	
	ON/OFF detection resistance	Recognizes as On at 1 K Ω or lower, and recognizes as Off at 10 K Ω or higher	
	Minimum detection time	0.25 seconds	
	Operation conditions	During operation/always	
	Contacts	Operation and stop/hold/step according to DI, user error screen can be customized	
Communication specifications	Applicable standards	RS485	
	Maximum number of connections	1:32 (Address 1 - 99)	
	Communication method	2-wire	
	Synchronization method	Asynchronous	
	Communication distance	Within approximately 1.2 km	
	Communication speed	9,600, 19,200, 38,400, 57,600, 115,200 bps	
	Data length	7/8 bits	
	Parity bit	NONE / EVEN / ODD	
	Stop bit	1/2 bit(s)	
	Protocol	PC-Link / PC-Link+SUM / MODBUS ASCII / MODBUS RTU	
	Response time	0 - 100 ms	

h Connection diagram

Display unit

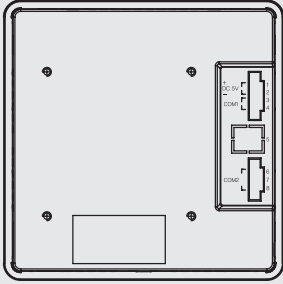

Terminal number	Power
1	+ DC 5V
2	
3	COM1 (Control unit)
4	

Terminal number	RS485 communication
6	RTX+
7	RTX-
8	

Power module

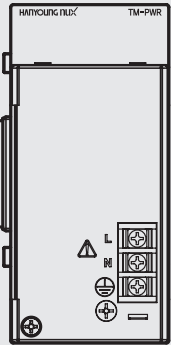

Terminal number	Power
L	 100 - 240 V a.c. 50 - 60 Hz 22 VA
N	
F.G.	 22 VA

Control module

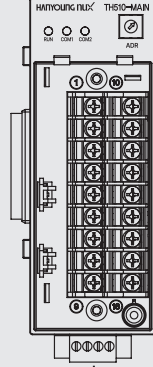

Terminal number	Temperature	Terminal number	Humidity
1	+ SSR/SCR	10	+ SSR/SCR
2	- SSR/SCR	11	- SSR/SCR
3	+ RET	12	+ RET
4	- RET	13	- RET
5		14	
6		15	
7	A RTD	16	A RTD
8	+ B mV/V	17	+ B mV/V
9	- B mV/V	18	- B mV/V

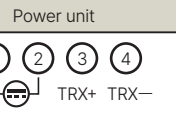

Input module

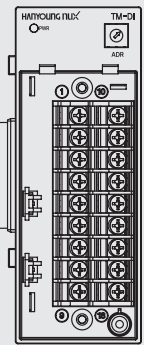

Terminal number	Input (1 - 8)	Terminal number	Input (9 - 16)
1	DI 1	10	DI 9
2	DI 2	11	DI 10
3	DI 3	12	DI 11
4	DI 4	13	DI 12
5	DI 5	14	DI 13
6	DI 6	15	DI 14
7	DI 7	16	DI 15
8	DI 8	17	DI 16
9	COM	18	COM

Output module

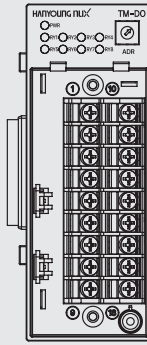

Terminal number	Output (1 - 4)	Terminal number	Output (5 - 8)
1	RY1	10	RY5
2	RY2	11	RY6
3	RY3	12	RY7
4	RY4	13	RY8
5		14	
6		15	
7		16	
8		17	
9		18	

Input/Output module

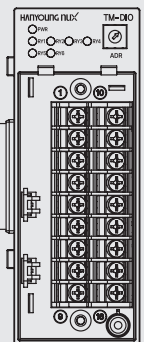

Terminal number	Input (1 - 8)	Terminal number	Output (1 - 6)
1	DI 1	10	RY1
2	DI 2	11	COM
3	DI 3	12	RY2
4	DI 4	13	RY3
5	DI 5	14	COM
6	DI 6	15	RY4
7	DI 7	16	RY5
8	DI 8	17	COM
9	COM	18	RY6

External dimensions and panel cutout dimensions

[Unit: mm]

Display unit

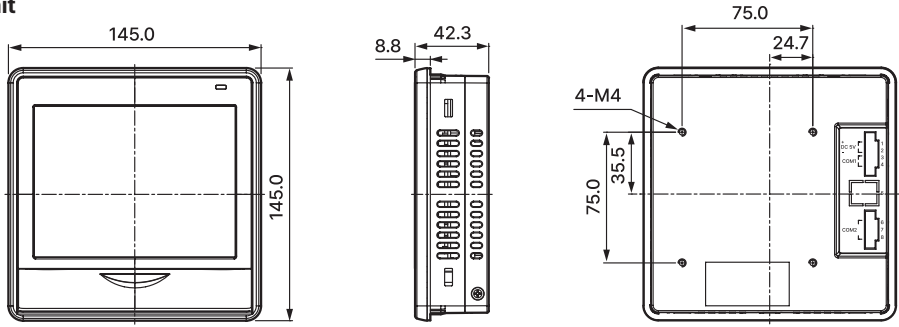

Power module

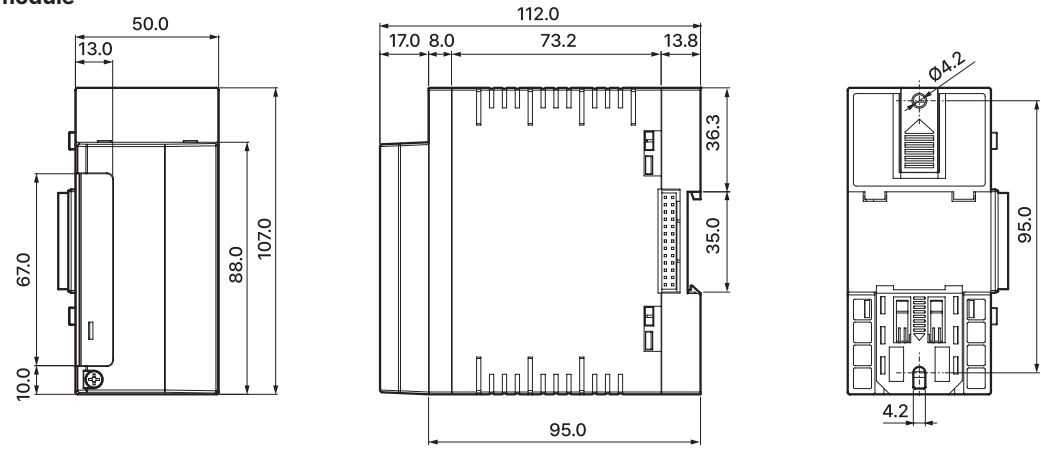

Control module, input module, output module, input/output module

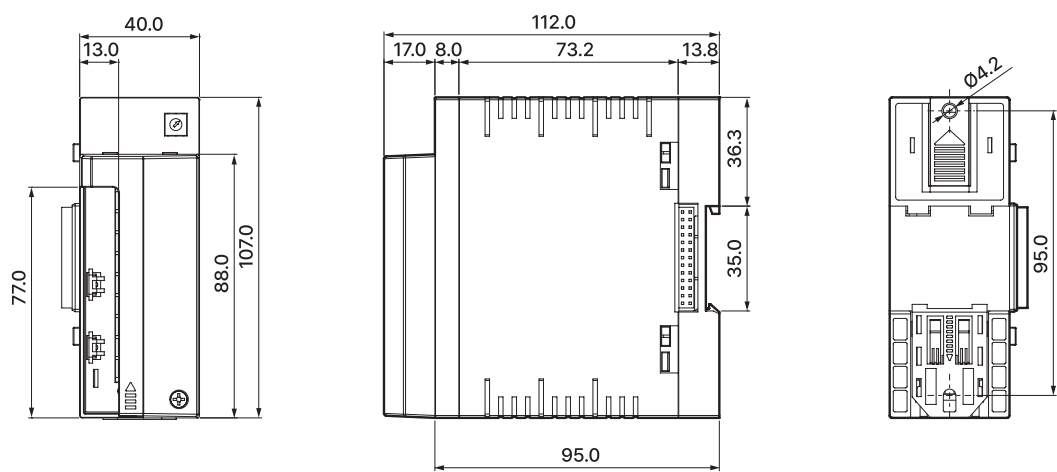

Panel cutout dimensions

