

Ethernet Comm. Type 2-Phase Closed-loop Stepper Motor Driver



AiC-D-MT Series PRODUCT MANUAL

For your safety, read and follow the considerations written in the instruction manual, other manuals and Autonics website.

The specifications, dimensions, etc. are subject to change without notice for product improvement. Some models may be discontinued without notice.

Features

- Closed-loop system with real-time position control
- High speed and high torque drive without missed steps
- Ethernet based Modbus TCP protocol
- Control up to 254 axes with Modbus TCP communication, with daisy-chaining method LAN connection (2 Port Ethernet switching hub included)
- Windows-based software (atMotion) for easy parameter setting and monitoring
- 7-segment display for alarm/status reading
- Built-in brake/gear/ rotary actuator type motors available

Safety Considerations

- Observe all 'Safety Considerations' for safe and proper operation to avoid hazards.
- ⚠ symbol indicates caution due to special circumstances in which hazards may occur.

⚠ Warning Failure to follow instructions may result in serious injury or death.

- 01. Fail-safe device must be installed when using the unit with machinery that may cause serious injury or substantial economic loss. (e.g. nuclear power control, medical equipment, ships, vehicles, railways, aircraft, combustion apparatus, safety equipment, crime / disaster prevention devices, etc.)**
Failure to follow this instruction may result in personal injury, economic loss or fire.
- 02. Do not use or store the unit in the place where flammable / explosive / corrosive gas, high humidity, direct sunlight, radiant heat, vibration, impact or salinity may be present.**
Failure to follow this instruction may result in explosion or fire.
- 03. Do not connect, repair, or inspect the unit while connected to a power source.**
Failure to follow this instruction may result in fire or electric shock.
- 04. Install the unit after considering counter plan against power failure.**
Failure to follow this instruction may result in personal injury, economic loss or fire.
- 05. Check 'Connections' before wiring.**
Failure to follow this instruction may result in fire.
- 06. Do not disassemble or modify the unit.**
Failure to follow this instruction may result in fire or electric shock.
- 07. Install the driver in the housing or ground it.**
Failure to follow this instruction may result in personal injury, fire or electronic shock.
- 08. Do not touch the unit during or after operation for a while.**
Failure to follow this instruction may result in burn or electric shock due to high temperature of the surface.
- 09. Emergency stop directly when error occurs.**
Failure to follow this instruction may result in personal injury or fire.

⚠ Caution Failure to follow instructions may result in injury or product damage.

- 01. When connecting the power input, use AWG18 (0.823 mm²) cable or over.**
- 02. Brake is non-polar. When connecting the brake, use AWG24 (0.2 mm²) cable or over.**
Failure to follow this instruction may result in fire or malfunction due to contact failure.
- 03. To use the motor safely, do not apply external force to the motor.**
- 04. It is recommended to use STOPPER for the vertical load.**
- 05. Install over-current prevention device (e.g. the current breaker, etc.) to connect the driver with power.**
Failure to follow this instruction may result in fire.
- 06. Check the control input signal before supplying power to the driver.**
Failure to follow this instruction may result in personal injury or product damage by unexpected driver movement.
- 07. Install a safety device to maintain the vertical position after turn off the power of the driver.**
Failure to follow this instruction may result in personal injury or product damage by releasing holding torque of the motor.
- 08. Use the unit within the rated specifications.**
Failure to follow this instruction may result in fire or product damage.
- 09. Use a dry cloth to clean the unit, and do not use water or organic solvent.**
Failure to follow this instruction may result in fire or electric shock.
- 10. The driver may overheat depending on the environment. Install the unit at the well-ventilated environment and forced cooling with a cooling fan.**
Failure to follow this instruction may result in product damage or degradation by heat.
- 11. Keep the product away from metal chip, dust, and wire residue which flow into the unit.**
Failure to follow this instruction may result in fire or product damage.
- 12. Use the designated motor only.**
Failure to follow this instruction may result in fire or product damage.

Cautions during Use

- Follow instructions in 'Cautions during Use'. Otherwise, it may cause unexpected accidents.
- Power supply should be insulated and limited voltage/current or Class 2, SELV power supply device.
- Re-supply power after 1 sec from disconnected power.
- In case of unwanted noise generating from peripherals and power, use ferrite core in the wiring.
- Keep the distance between power cable and signal cable over 10 cm.
- The thickness of cable should be same or thicker than the below specifications when connecting the cable for connector.
 - Power connector (PWR): AWG18
 - Motor + Encoder connector (MOTOR): AWG22, AWG24
 - I/O connector (SIGNAL I/O): AWG28
 - Brake connector (BRAKE): AWG24
- Motor vibration and noise may occur in a specific frequency range.
 - Change the motor installation method or attach the damper.
 - Use the unit out of the corresponding frequency range due to changing motor RUN speed.
- Maintain and inspect regularly the following lists.
 - Unwinding bolts and connection parts for the unit installation and load connection
 - Abnormal sound from ball-bearing of the unit
 - Damage and stress of lead cable of the unit
 - Connection error with motor
 - Inconsistency between the axis of motor output and the center, concentric (eccentric, declination) of the load, etc.
- This product does not contain a protection function for a motor unit.
- This unit may be used in the following environments.
 - Indoors (in the environment condition rated in 'Specifications')
 - Altitude max. 2,000 m
 - Pollution degree 2
 - Installation category II

Cautions during Installation

- Install on the metal plate with high thermal conductivity for heat dissipation of the driver.
- Install in the well-ventilated area and install the cooling fan in the unventilated environment.
- Failure to heat dissipation may result in damage or malfunction due to the stress on the product. Check the environment of use within the specifications and install on the well-heat dissipated area.
- In case of installing the drivers more than two, keep distance at least 20 mm in horizontal direction and at least 25 mm in vertical direction.

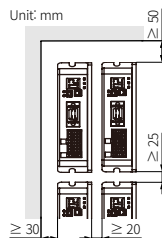

Ordering Information

This is only for reference, the actual product does not support all combinations. For selecting the specified model, follow the Autonics website. Select a model that matches the ordering information of the motor and the driver.

AiC - D - ① ② ③ - ④ - MT

① Frame size

Number: Frame size (mm)

② Axial length

S: Short
M: Medium
L: Long

③ Encoder resolution

A: 10,000 PPR (2,500 PPR × 4)

④ Motor type

No mark: Standard type
B: Built-in brake type

Product Components

- Product
- Instruction manual
- Power connector × 1
- I/O connector × 1
- Brake connector (AiC-D-B-MT Series) × 1

Manual

For proper use of the product, refer to the manuals and be sure to follow the safety considerations in the manuals. Download the manuals from the Autonics website.

Software

Download the installation file and the manuals from the Autonics website.

■ atMotion

The program allows to manage the motor driver's parameter setting and monitoring data.

Sold Separately

- Power cable: CO-PW-□
- I/O cable: CO20-MP□-R
- Motor + Encoder cable: C1D14M(B)-□ (fixed type), C1DF14M(B)-□ (flexible type)

Dimensions

- Unit: mm, For the detailed drawings, follow the Autonics website.

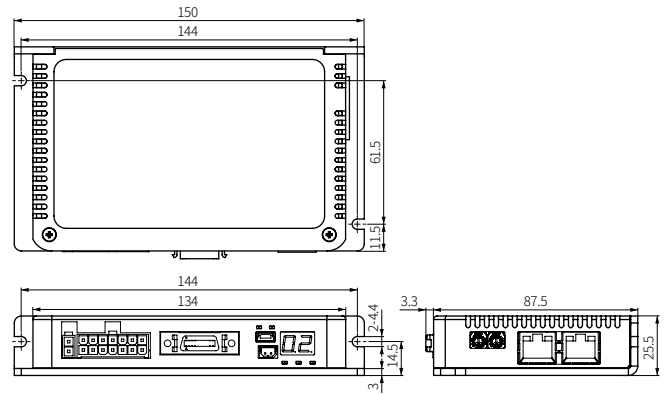

Unit Descriptions

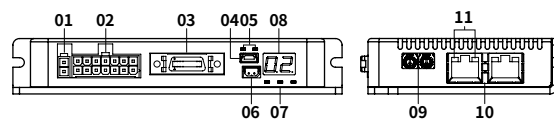

- 01. Power connector**
- 02. Motor + Encoder connector**
- 03. I/O connector**
- 04. USB connector**
- 05. Ethernet status indicators**
- 06. Brake connector (AiC-D-B-MT Series)**
- 07. Status indicators**
- 08. Status & IP display part**
- 09. Comm. IP setting rotary switch**
- 10. Comm. connector**
- 11. Comm. indicator**

Status Display Part / Indicators

Display part / Indicator	Color	Descriptions
Status display part (7-segment)	Red	Displays Ethernet IP Displays the corresponding number, operation when alarm / warning occurs
Servo ON / OFF indicator (SERVO)	Orange	Turns ON when servo is ON, Turns OFF when servo is OFF
In-Position indicator (INP)	Yellow	Turns ON when motor is placed at command position after positioning input
Power / Alarm indicator (PWR/AL)	Green	Turns ON when the unit operates in normal after power input Flashes when warning occurs
	Red	Flashes when alarm occurs
Ethernet Error indicator (ERR)	Red	Turns ON when communication error occurs
Ethernet RUN indicator (RUN)	Green	Turns ON when communication connected

Alarm / Warning

The status display part displays segment depending on Alarm / Warning type. Depending on the alarm / warning type, it flashes for 0.4 sec interval and it turns OFF for 0.8 sec repeatedly. For more information of Alarm / Warning, refer to 'User manual'.

■ Alarm

Display	Alarm type	Display	Alarm type
E.1	Overcurrent error	E.A	Input speed error
E.2	Overspeed error	E.b	Supply voltage error
E.3	Position deviation error	E.C	In-Position error
E.4	Overload error	E.d	Memory error
E.5	Overheat error	E.E	Emergency stop
E.6	Motor connection error	E.F	Program mode error
E.7	Encoder connection error	E.G	Index mode error
E.8	Regenerative voltage error	E.H	Home mode error
E.9	Motor alignment error	E.J	Position moving value overflow

■ Warning

Display	Warning type	Display	Warning type
W.1	+Software limit	W.5	Overload warning
W.2	-Software limit	W.6	Override warning
W.3	+Hardware limit	W.7	Position offset warning
W.4	-Hardware limit	W.8	DHCP fail warning

Specifications

Model	AiC-D-42□A-MT	AiC-D-56□A-MT	AiC-D-60□A-MT
	AiC-D-42□A-B-MT	AiC-D-56□A-B-MT	AiC-D-60□A-B-MT
Power supply	24 VDC± 10%		
Permissible voltage range	90 to 110% of rated voltage		
Max. RUN power ⁽⁰¹⁾	≤ 60 W	≤ 120 W	≤ 240 W
Stop power ⁽⁰²⁾	≤ 10 W	≤ 12 W	≤ 15 W
Max. RUN current ⁽⁰³⁾	1.7 A / Phase		
Stop current	20 to 100% of max. RUN current		
Resolution	500 (factory default), 1000, 1600, 2000, 3200, 3600, 5000, 6400, 7200, 10000 PPR		

01) When changing the load rapidly, instantaneous peak current may increase. The capacity of power supply should be over 1.5 to 2 times of max. RUN power.

02) Based on ambient temp. 25°C, ambient humi. 55%RH, stop current 50%

03) RUN current varies depending on the input RUN frequency and max. RUN current at the moment varies also depending on the load change.

Run method	2-phase bipolar closed-loop control method
Speed filter	Disable, 2, 4, 6, 8, 10, 20, 40, 60 (factory default), 80, 100, 120, 140, 160, 180, 200 ms
Control Gain	0 (factory default) to 14, 15 (Fine Gain)
Max. rotation speed	3,000 rpm
Position setting range	-2,147,483,648 to 2,147,483,647 (resolution setting: 10,000)
In-Position	Fast Response: 0 (factory default) to 7, Accurate Response: 0 to 7
Operation mode	Jog mode / Continuous mode / Index mode / Program mode / Homing mode / Position determining mode
Home search	Home Search, Limit Home Search, Zero point Home Search, Torque Home Search
No. of program step	256-step
Program function	Power On Program Start, Power On Home Search
Control command	ABS, INC, HOM, ICJ, IRD, OPC, OPT, JMP, REP, RPE, END, POS, TIM, CMP
Input	Exclusive input: 3 (ORG, +Limit, -Limit), General input: 9
Output	General output: 6, Brake output: 2 (built-in brake type)
External power supply	VEX (Default: 24 VDC±), GEX (GND)
Insulation resistance	≥ 100 MΩ (500 VDC± megger)
Dielectric strength	Between the all charging part and the case: 1,000 VAC~ 60 Hz for 1 minute
Vibration	1.5 mm double amplitude at frequency 10 to 55 Hz in each X, Y, Z direction for 2 hours
Shock	300 m/s ² (≈ 30 G) in each X, Y, Z direction for 3 times
Ambient temp.	0 to 50°C, storage: -10 to 60°C (no freezing or condensation)
Ambient humi.	35 to 85%RH, storage: 10 to 90%RH (no freezing or condensation)
Certification	CE
Unit weight (packaged)	≈ 330 g (≈ 460 g)

Communication Interface

Ethernet

Comm. specifications	Ethernet Modbus TCP
Physical layer / Protocol	100BASE-TX
Connection cable	CAT5e class over or Modbus association approval product
Comm. distance	Within 100 m distance between nodes
Baud rate	10 / 100 Mbps
IP Address setting	Sets to IP setting switch or internal parameter
Topology	Star, Line, Tree

Troubleshooting

Malfunction	Causes	Troubleshooting
When communication is not connected	The communication cable is not connected.	Check communication cable wiring. Check communication cable connected correctly.
	The communication IP and the communication port settings are not correct.	Check the connected communication IP and communication port settings are correct.
When motor does not excite	Servo ON is not.	Check the Servo On signal. Check the Motor Free signal.
	Alarm occurs.	Check the alarm type and remove the cause.
When motor rotates to the opposite direction of the designated direction	Motor Direction parameter setting is not correct.	Check the Motor Direction parameter settings.
	Connection between motor and encoder is unstable.	Check the driver and motor are connected correctly.
When motor drives unstable	Control Gain value is not correct.	Change the Control Gain parameter as the appropriate value.
	The combination of the driver and motor models is not correct.	Check the model combination.

EMC Measures

Noise filter for signal line

Connect to wiring to suppress external noise. Depending on frequency, filtered noise may different.

Type	Model	Manufacture
Motor line	28A5776-0A2	Lairdtech

Noise filter for power

Connect the power to suppress external noise. The wires should be connected as short as possible and grounded.

Model	Specifications	Manufacture
RNS-2010	Rated voltage: 250 V Rated current: 10 A Max. leakage current: 1 mA	Orient Electronics

Connectors

Power connector (PWR)

Pin	Function
1	24 VDC ±
2	GND

Motor + Encoder connector (MOTOR)

Pin	Function	Pin	Function
1	GND	8	+5 VDC±
2	Encoder A	9	Encoder \bar{A}
3	Encoder B	10	Encoder \bar{B}
4	Encoder Z	11	Encoder \bar{Z}
5	GND EARTH	12	N-C
6	Motor A	13	Motor B
7	Motor \bar{A}	14	Motor \bar{B}

I/O connector (SIGNAL I/O)

Pin	Function	Pin	Function
1	VEX	11	IN3
2	ORG	12	IN4
3	+Limit	13	IN5
4	-Limit	14	OUT5
5	IN6	15	OUT6
6	IN7	16	OUT1
7	IN8	17	OUT2
8	IN9	18	OUT3
9	IN1	19	OUT4
10	IN2	20	GEX

USB connector (COM)

Pin	Function	Pin	Function
1	V BUS	4	N-C
2	Data -	5	GND
3	Data +	-	-

Brake connector (BRAKE)

• Only available in built-in brake type.

Pin	Function
1	GND
2	24 VDC ±

Ethernet communication Connector (LINK 1 / LINK 2)

Pin	Function	Pin	Function
1	TD+	5	-
2	TD-	6	RD-
3	RD+	7	-
4	-	8	-

Suitable specifications

- The following connectors can be used with equivalent or substitute.
- Ethernet dedicated cable must be used and the performance can not be guaranteed when using other cables.

Type	Connector specifications	Manufacture
PWR	Power connector CHD1140-02, connector terminal: CTD1140	HANLIM
MOTOR	Motor + Encoder connector 5557-14R, connector terminal: 5556T	Molex
SIGNAL I/O	I/O connector 10120-3000PE, Housing: 10250-52F0-008	3M
	CO20-MP□-R (Sold separately)	Autonics
COM	USB connector USB	-
BRAKE	Brake connector 5264-02, connector terminal: 5263PBT	Molex
LINK 1	Ethernet comm. connector RJ45	-
LINK 2		

Switch

■ Communication IP setting rotary switch (SW201, SW200)

- IP setting with the switch combination (0x00 to 0xFF)

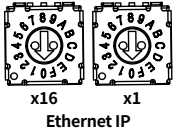

Switch values	Descriptions
0x00	Sets the IP Address parameter value to IP
0x01 to 0xFE	Sets the IP Switch value to the last address Ex) Switch value: 0x0A => IP Address: 192.168.0.10
0xFF	Assigns the IP address with DHCP

Network Setting

- Configure the network settings from the Communication Group of the atMotion (PC).
- For the initial IP address, refer to the table as follows.

IP Address	192.168.0.3
Subnet Mask	255.255.255.0
Gateway	192.168.0.1

Connections

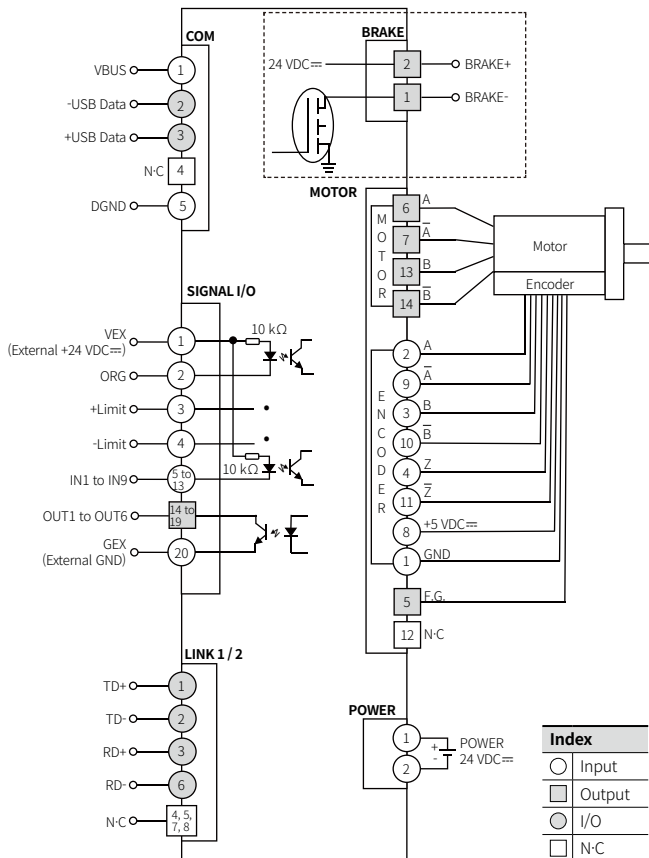

- ⊞ is only available in built-in brake type.

Index	
○	Input
□	Output
⊞	I/O
⊞	N-C

Sold Separately : Power Cable

■ CO-PW-□

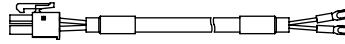

- Recommended to use ferrite core at both ends of the cable.
- The model name is 010, 020 which indicates the cable length.
E.g.) CO-PW-010: 1 m power cable

Sold Separately : Motor + Encoder Cable

■ Fixed type: C1D14M(B)-□, Flexible type(B): C1DF14M-□

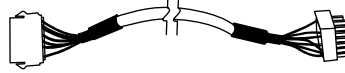

- Recommended to use ferrite core at both ends of the cable.
- The model name is 1, 2, 3, 5, 7, 10, 15, 20 which indicates the cable length.
E.g.) C1DF14M-10: 10 m flexible type Motor + Encoder cable
- For built-in brake type, use dedicated cable.
(fixed type: C1D14MB-□, flexible type: C1DF14MB-□)

Sold Separately : I/O Cable

■ CO20-MP□-R

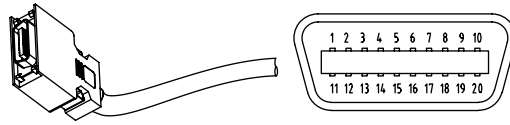

Pin	Function (Name TAG)	Cable Color	Dot line color-number
1	VEX	Yellow	Black-1
2	ORG		Red-1
3	+Limit		Black-2
4	-Limit		Red-2
5	IN6		Black-3
6	IN7		Red-3
7	IN8		Black-4
8	IN9		Red-4
9	IN1		Black-5
10	IN2		Red-5
11	IN3	White	Black-1
12	IN4		Red-1
13	IN5		Black-2
14	OUT5		Red-2
15	OUT6		Black-3
16	OUT1		Red-3
17	OUT2		Black-4
18	OUT3		Red-4
19	OUT4		Black-5
20	GEX		Red-5

- Recommended to use ferrite core at both ends of the cable.
- The model name is 010, 020, 030, 050, 070, 100, 150, 200 which indicates the cable length.
E.g.) CO20-MP070-R: 7 m I/O cable